

Pierrot Lunaire

Eine blasse Waescherin (Number 4)

A pallid washerwoman
Washes pale kerchiefs by night;
She stretches naked, silver-white arms
Down into the stream.

Through the glade slink winds,
gently moving the current.

A pallid washerwoman
Washes pale kerchiefs by night.
And the gentle maiden of the heavens,
Delicately flattered by the branches,
Spreads over the dark meadow
Her light-woven linen--
A pallid washerwoman.

(A.F.)

Schoenberg Op. 21/4 - Primary Hexachords

Phillips

m. 15 16 17 18

4-19 6-21 6-244/19

6-15
 FL 7----- 5 8 1 7 5 4 5 4 1 9-- AB 9----- AB 9----- AB 9

6-21
 CL 9-----6----- 9--0 8 9 2 0 A-- A----- A----- A

6-243/17
 VN B----- 4 3 5 3 B 0 9 7-- 2 7 2-- 7 2

RC 6 4 1 2 1 5 1 2 4 5 4 5 7 2 1 1 2-----1 4 3 2-----

6-211/40 8-9 (coda) 6-242/13

begins with 3-10

~~1 2 3 4 5 6~~
 1 2 3 4 5 6
 1 1 1

1 9
 2 0 A
 0 9 7 2
 7 2 1

6-211/40 (above)

Schoenberg Op. 21, No. 4
 Eine blasse Wascherin (trans. J.P.)

FORM

A Pale Washerwoman

mm. 1 - 5 intro

A pale washerwoman
 washes nightly pale fabrics,
 stretching her naked, silver-white arms
 down into the flood.

6 - 9 a A
 b
 c
 d

Winds steal through the glade
 gently stirring the stream.
 A pale washerwoman
 washes nightly pale fabrics.

9 - 13 e B
 f
 a
 b

And the gentle maid of heaven,
 tenderly caressed by the branches,
 spreads her light-woven linen
 upon the dusky meadow -
 A pale washerwoman.

13 - 16 g A
 h
 i
 j
 17 - 18 a coda

m. 1 2 3 4 5 6

7-16 7-19 7-21 5-28

FL	5 4	B 2--	5 7	4	9 1	6	3	4
CL	2--	5 4 B---		8 2 4	7	8	8	
VN	B--	2 B 5 2 3		1 5 8	0	B	9	
RC								

5-16 5-19 5-16 5-16 7-28

CL 2 5 4 B 8 2 4

5-31 (above)

5-20 ends intro and coda

w/pc

m. 7 8 9

(6-244) 7-19 5-19 7-19 7-21

FL	B 4	5 9 6	4--	0 9--	B	9 7 6 5	5 4
CL	4 6	1 0 2	9--	0 4 3 6		4 2 4 1	1 9
VN	9 3	2 B A	3--	0 A--	0	3--	2 6 7
RC	2 A	B--	7 5 2 1	3--	2 0 4 A 9--	1 A B-	

5-16 7-28 5-19 5-16 5-19 5-19 5-19 7-28 7-31

5 1 2

0 4 A 9-- 1 A B

5-16 (above)

m. 10

11

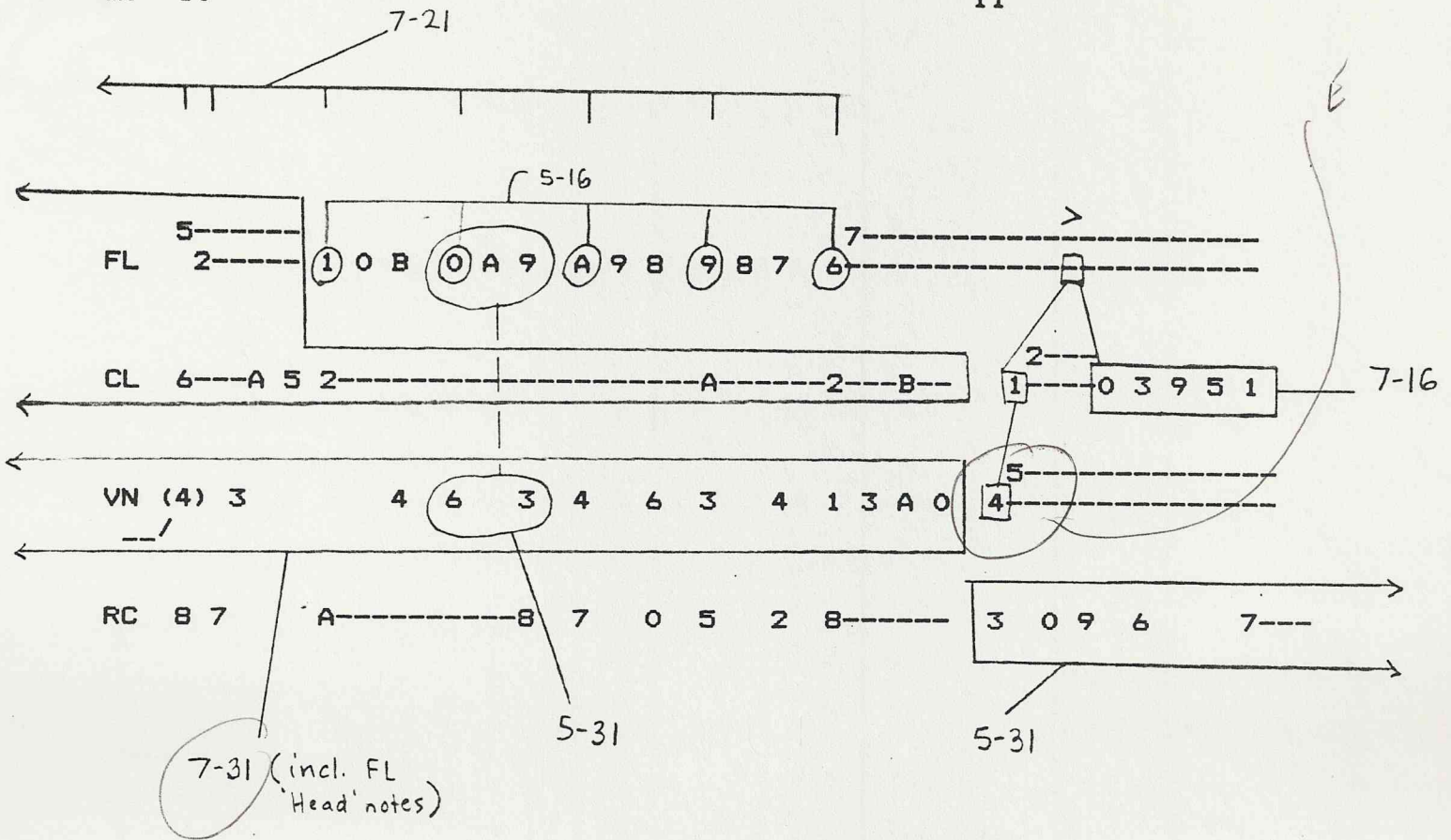

Imitation below - starts on "E" - significant pc in this song. (as are its NT's)

FL 4 2 0
 VN 4 2 0
 RC 4 2 0

m. 12

13

14

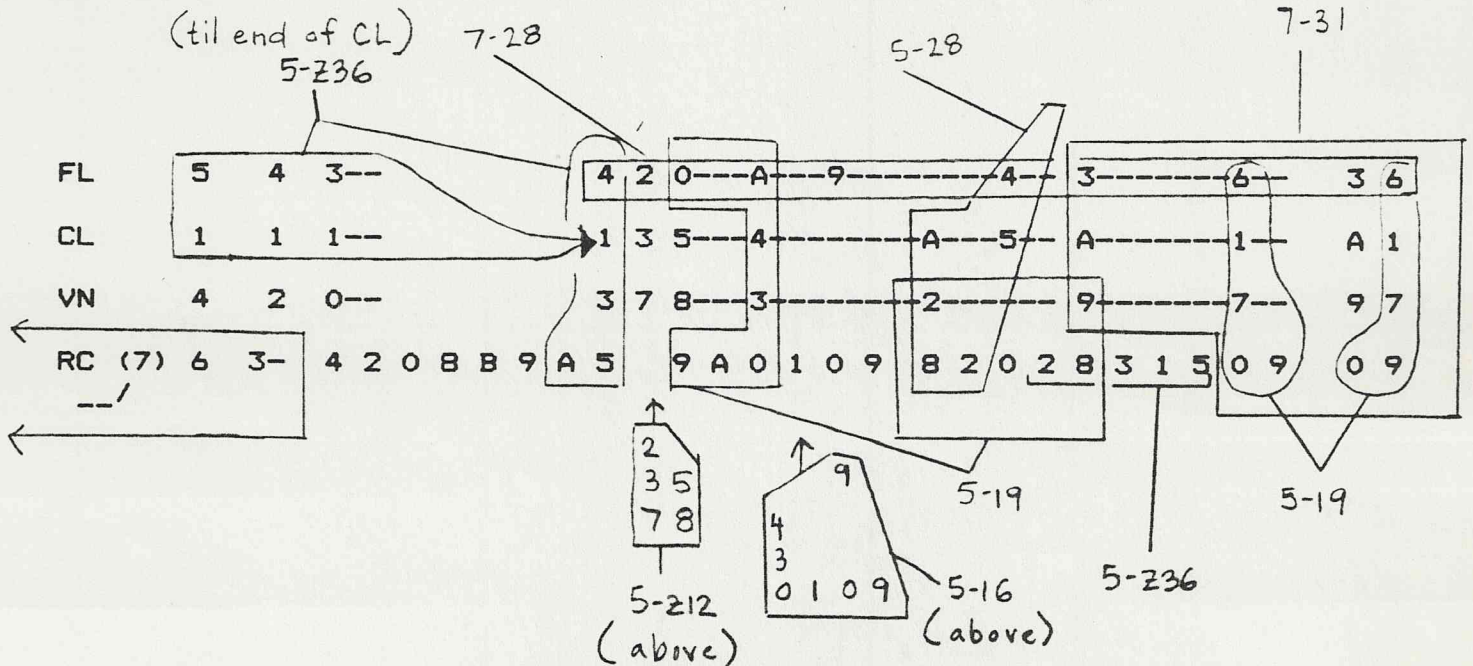

m. 15

16

17

18

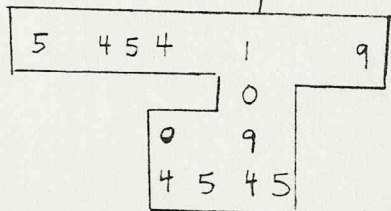
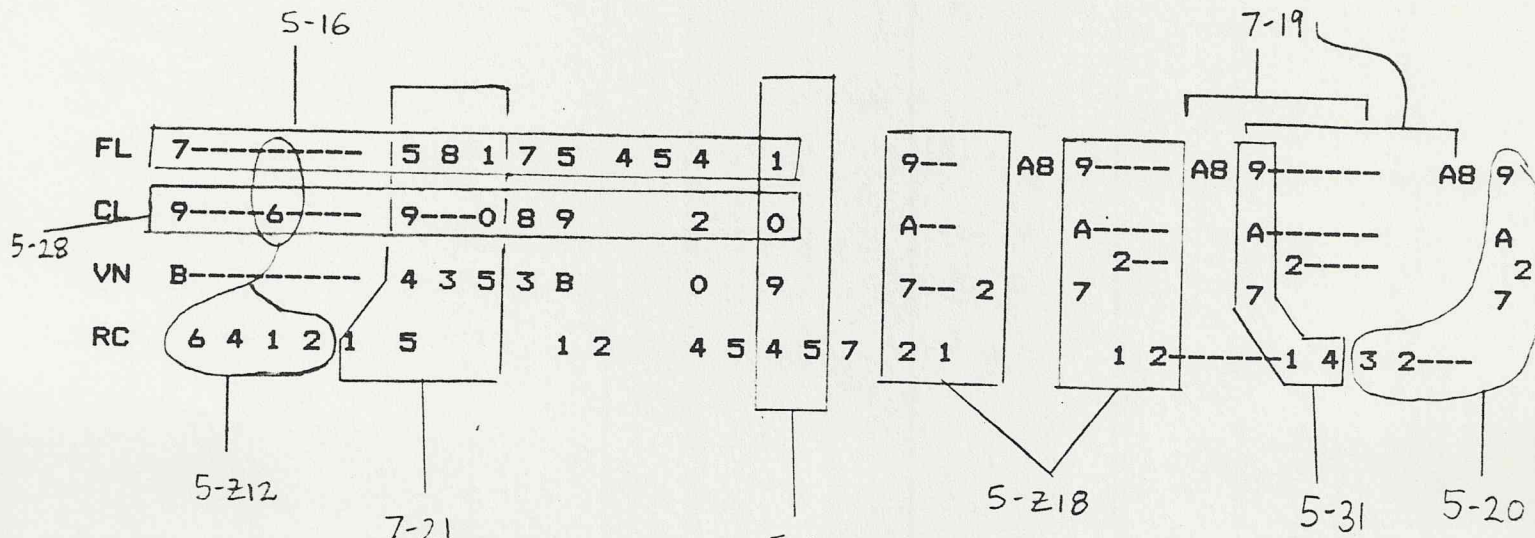

(above)

Why does S. give the Klavierauszug?

Check 2-28 (total 'Pisost' motion)

Schoenberg, Op. 21/4 Eine blasse Wäscherin

CLOSELY RELATED TO FIRST PIECE W/R PC SETS

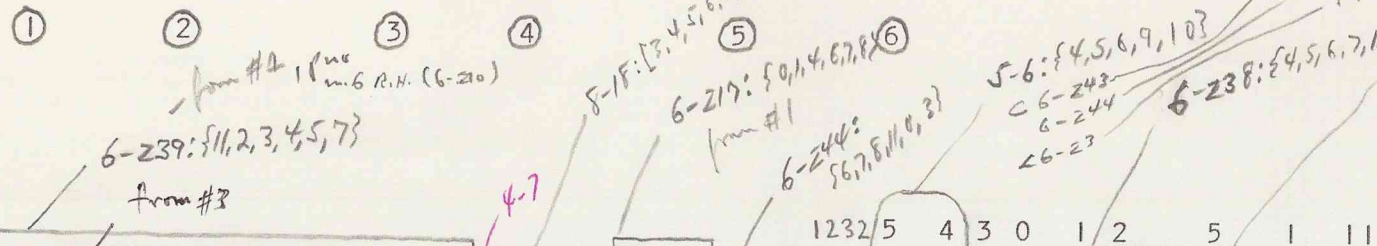

Rez.

Klav. Auszug

dim. triad as symbol

4-27 {11, 2, 5, 7}

4-13: {1, 2, 4, 5} < 6-217

5-26: {1, 2, 3, 5, 7} < 6-21, 6-237

6-219: {1, 2, 4, 5, 8, 9} = IT₆ 6-219 pc 6 inv.

5-20: {8, 9, 11, 3, 4} < 6-219 (pc 0) < 6-243 (pc 5)

6-213: {3, 4, 6, 7, 9, 10} from #1

4-19: {3, 4, 7, 11}

6-243: {4, 5, 6, 9, 10, 0} from #1

6-15: {3, 4, 5, 7, 8, 11}

5-6: {4, 5, 6, 9, 10} (IT₂) < 6-243 + pc 2 < 6-244 + pc 7 < 6-23 + pc 7 < 6-26 + pc 3

Klav. Auszug conceals sets formed by sep. instruments

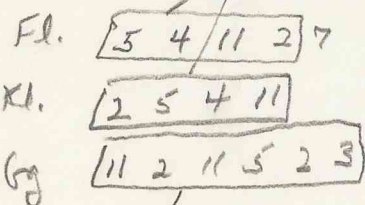

4-12: {1, 2, 3, 5}

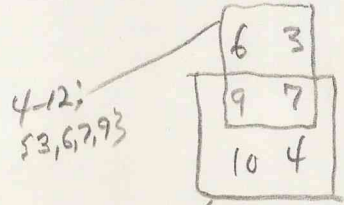

4-12: {3, 6, 7, 9}

4-13: {4, 7, 9, 10}

A peculiarity of this piece is the large number of 8ve-relations in indiv. parts - c.s. Kl. in mm. 1-2

Example of 'Hexachordal mutation!'

Schoenberg, Op. 21/4

⑦ Rez. ? 6-212: {1,2,3,5,7,8}

⑧ 5-19: {9,10,11,0,3,4,6} → 6-242: {9,10,11,0,3,6}
 [5-19: {9,10,0,3,4}] → 6-243: {10,11,0,3,4,6}
 = 6-217 + pc 8
 = 6-213 + pc 2

⑨

Rez. 2 10 8 7 7 5 2 1 3 2 0 4 10 9 9 1 10 11

Klav. Auszug

11	3	1	9	10		3	0	9	11	3	4	1	6	9	
9	6	5	0	6		4		10	0	9	2	3	2	1	7
4	4	2	11	2		9		4	3	6	4	7	6	5	4

4-27 (cf. op. 11)

5-29: {3,4,6,9,11}?

6-239: {9,11,0,1,2,5}

6-239: {6,9,10,11,0,2}

6-217: {2,3,4,6,9,10}

4-18: {9,0,3,4}

4-229: {9,10,0,4}

4-18: {11,0,3,6}

4-23 4-7 4-3

5-14 6-1

5-2

8-2:

6-239: {11,0,3,6,7,9}

II₁₁ (4-10 inv) 9,11,0,2

Here, the sum of instrumental parts = 10-1. The introduction of pcs 8 and 9 in Rez. completes a 12-note aggregate

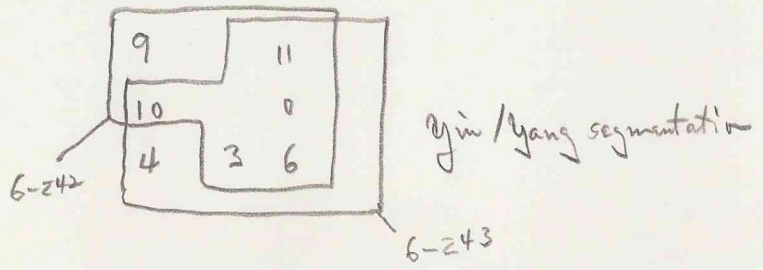

Shows 5-238: {10,11,0,3,6}

⑩

Rez.	10	11	9	8	6	7	8	7	10
Klav.	4		4		10	11	10	4	10
Auszug.	5	5	5	5	2		5	2	5
	8				10	11	10	6	3

again

ϕ -ZIS: {4,5,8,10}

ϕ -ZIS: {10,11,2,4}

T₆

? ϕ -1: {2,3,4,5,6}

ϕ -3: {2,3,5,6}

ϕ -12: {2,4,5,6}

8	7	0	5	2	8
6	3	4	6	3	11
10	9	10	9	8	10
9	8	7	7	6	

? ϕ -Z23: {10,0,1,3,4,6}

Geige

6-249 in m. 14
 6-228: {8,10,0,2,3,6}
 6-22: {2,4,6,8,9,10}
 6-5: {3,4,7,8,9,10}
 8-19: {4,5,8,0}

The segmentation of m. 10 is difficult - and problematic

(11)

(12)

(13)

Rez.	3	0	9	6	7	7	6	3	4	2	0	8	11	9	10	5	9	10	0	1	0	98	2	0	2
Klav.		5		5													3	2	5		3				4
Auszug	7	4		4					4	2	0						3	2	5		3				4
	6								5	4	3						4	7	0		10	9	9	5	
		1	2	1	2	1	2	1	2	1	2	0	3	9	5	1		1	3	8		4		2	2
																									10

4-3: [1, 2, 4, 5]

6-239: {9, 0, 1, 2, 3, 5}

6-23: {1, 2, 4, 5, 6, 7}

8-13: (8, 10, 11, 2)

4-3: [1, 2, 4, 5]
 ? 6-1: {0, 1, 2, 3, 4, 5}

8-4: (6, 9, 10, 11)

Flute: 5-19: {2, 4, 6, 9, 10}
 Kl.: 4-18: {10, 11, 4, 5}
 Vg: 4-16: {2, 3, 7, 9}

14

15

16

(sung)

Rez. 7 3 1 5 0 9 0 9 6 4 1 2 1 5 1 1 2 4 5 4 5 7 2 1

Klav.

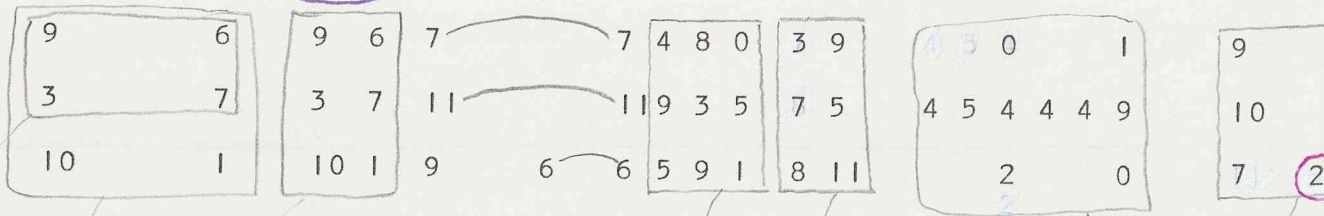

Auszug

4-12: {3,6,7,9}

6-24: {6,7,9,10,1,3}

? 4-10: {6,7,9,11}

5-21: {8,9,0,1,3,4,5}

6-21: {3,5,7,8,9,11}

moon symbol

6-14: {9,0,1,2,4,5}

4-14: {7,9,10,2}

open

Schoenberg, Op. 21/4

(17)

(18)

Rez.

1 1 2

1 4 3 2

Klav.

10	8	9
	10	
	7	2

10	8	9
	10	
	7	2

10 8 9 9

Auszug

10 10

7 2 2

5-5:

{7, 8, 9, 10, 2}

Schoenberg Op. 21/4 - Primary Hexachords

Phillips

m. 1 2 3 4 5 6

FL	5 4 B 2-- 5 7	4 9 1	6 3	4	9 3 4 6 4--7
CL	2-- 5 4 B----	8 2 4	7 8	8	(A) 7--0 9 (B) B
VN	B-- 2 B 5 2 3	1 5 8	0 8	9	6 (4) (B) 5 (A) 5 3
RC				1 2 3 2	5 4 3 0 1 2 5 1 B

6-239/10 6-219/44 6-217/43 6-244/19 6-213/42 6-15

6-238/10

* B^b completes chrom.
 circled notes form 6-239
 (lower melody of VL)
 see pno. reduction

m. 7 8 9

FL	B 4 5 9 6	4-- 0 9-- B	9 7 6 5	5 4	5-- 2--
CL	4 6 1 0 2	9-- 0 4 3 6	4 2 4 1	1 9	8-- A B A--
VN	9 3 2 B A	3-- 0 A-- 0	3-- 2	6 7	4--
RC	2 A	8-- 7 5 2 1	3-- 2 0 4 A 9-- 1 A B--		A B 9 8

6-244/19 6-243/17 6-211/40 6-228/49

(6-15)

6-240/11

6-217

6-239

6-210

5 9 6

1 0 2

2 B A

8 7

6-21

6-210/39

6-219/44

6-239/10

6-210/39

Schoenberg Op. 21/4 - Primary Hexachords

Phillips

"Head" notes IN FL + CL = 6-15
(circled below)

m. 10

11

6-228/49

6-239/10

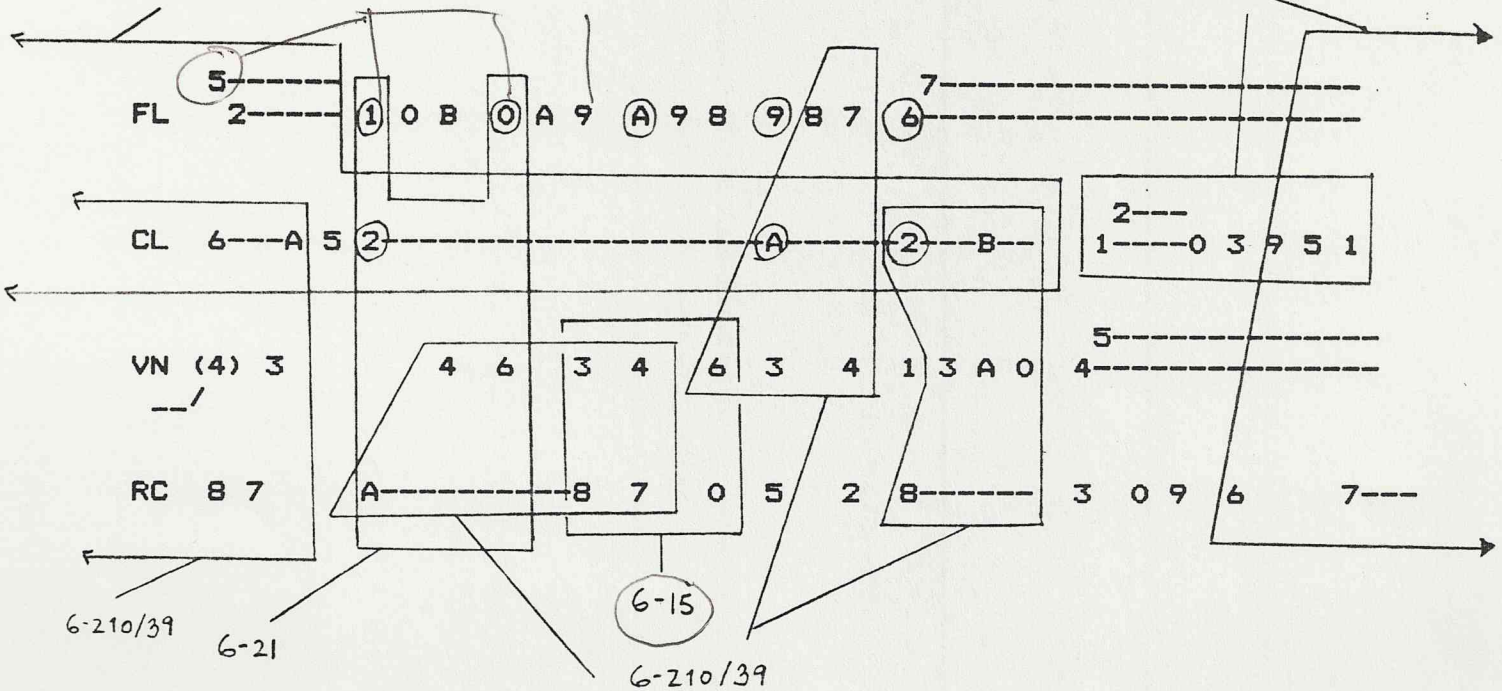

m. 12

13

14

6-239/10

6-238

6-249/28

